

Manual

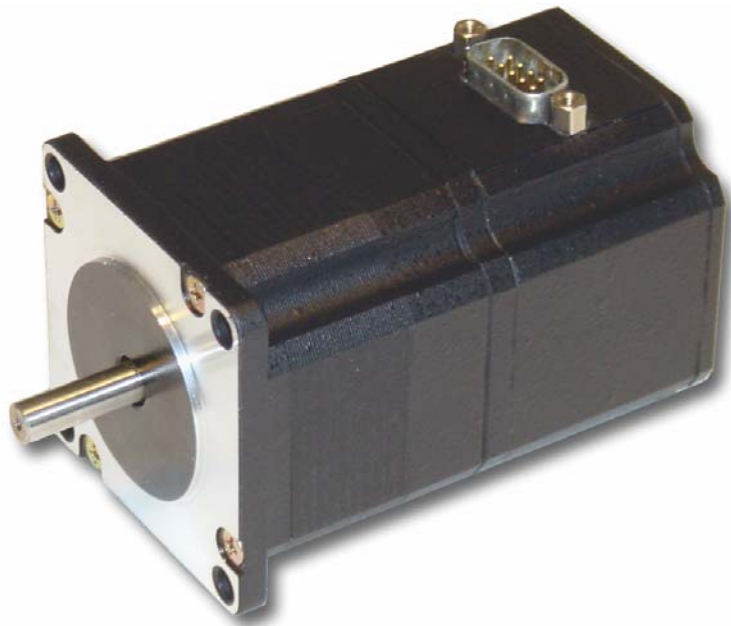
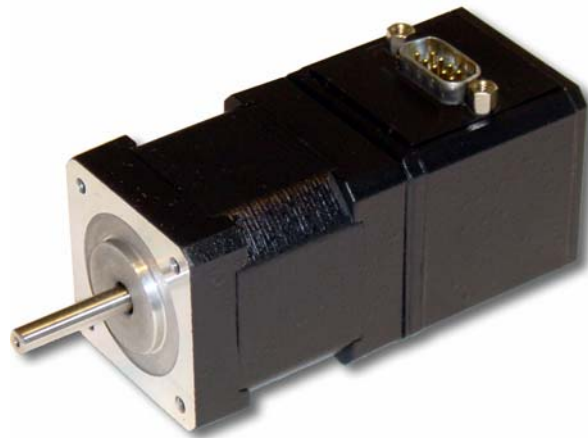

Plug & Drive

PD2

© 2002

Nanotec® Electronic GmbH

Gewerbestr. 11

85652 Landsham / Pliening

Phone:(089) 900 686-0

Fax: (089) 900 686-50

Internet: www.nanotec.com

All rights reserved.

This documentation is to be read through carefully before installation and commissioning.

In the interests of its customers, Nanotec® reserves the right to make technical alterations and developments to hard- and software to improve the functioning of this product without giving special prior notice.

This manual was written with the necessary care. It is exclusively intended for the technical description of the product and to give instructions for commissioning. In accordance with our general terms of business, the warranty extends exclusively to repair or replacement of defective devices. Liability for consequential damage and sequence error is ruled out. The valid norms and regulations are to be observed in the installation of the device.

For criticism, proposals and suggestions for improvement, please contact the address given above or send an email to:

Info@nanotec.de

Contents

1.	Product Description	-4-
1.1	General	-4-
1.2	Side View	-4-
2.	Connections and Settings	-5-
2.1	Connections SUBD-9	-5-
2.2	Operating Voltage	-6-
2.3	Inputs	-6-
2.4	DIP-Switches	-7-
3.	Commissioning	-9-
3.1	Safety Instructions	-9-
3.2	ESD-Safety Measures	-9-
3.3	Measures for interference suppression	-9-
3.4	Connection of device	-10-
3.5	Causes of faults	-10-
4.	Technical Characteristics	-11-
5.	Dimensions	-12-
5.1	PD2-T4218...	-12-
5.2	PD2-T5718...	-13-

1. Product Description

1.1 General

In the Plug & Drive Motor PD2, microstep driver and stepper motor are combined in one device. Step precisions from full to a tenth of a step and phase currents from 0.4 to 1.8 A can be selected via DIP switch with a supply voltage of 24 to 48 V (only for PD2-T42xx). The controlling of the optically decoupled inputs CLK (clock) and DIR (direction) can take place with 5 V as well as with 24 V signals. In order to reduce the thermal load of the motor at rest, the phase current is automatically reduced by 50% after a clock pause of 80 ms.

1.2 Side view

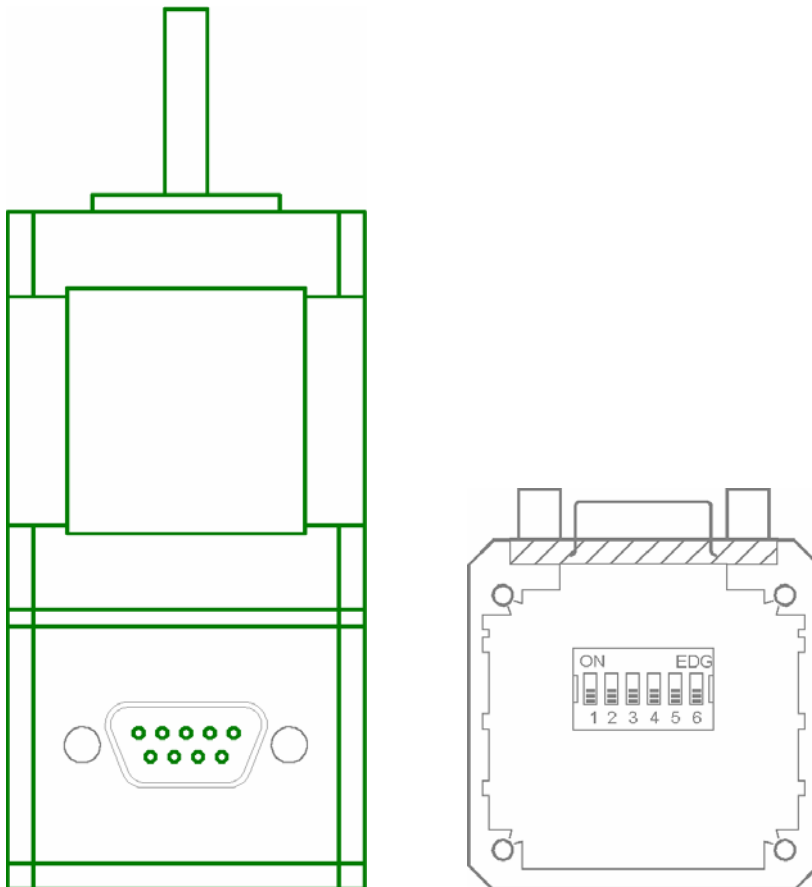

2. Connections and Settings

2.1 Connections SUBD-9

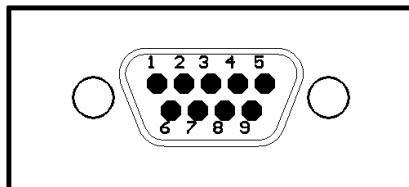

Pin Nr.	Function
1	Power +24 ... 48 V DC (only 24 V DC for PD2-T57xx)
2	DIR (Direction) +5 V
3	CLK (Clock) +5 V
4	CLK (Clock) +24 V
5	Power GND
6	DIR (Direction) -
7	DIR (Direction) +24 V
8	CLK (Clock) -
9	NC

2.2 Operating Voltage

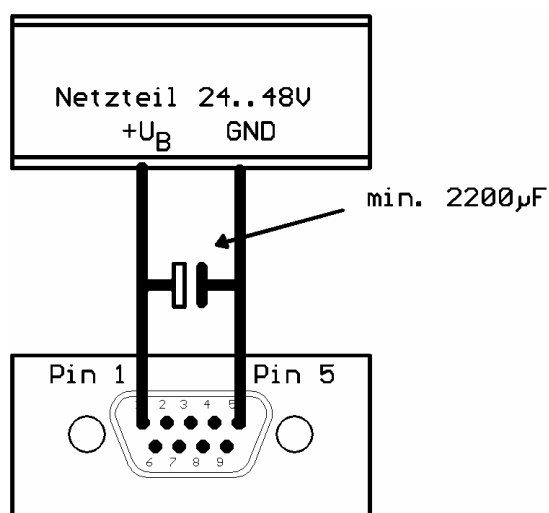

The permitted operating voltage of PD2 lies in the range from 24 to 48 V DC (24 V DC for PD2-T57xx) and must under no circumstances exceed 50 V (27 V for PD2-T57xx) or fall below 21 V. A charging capacitor of at least 2200 μF must be provided at the supply voltage, in order to avoid exceeding the permitted operating voltage (e.g. with braking procedure).



Connect a charging capacitor of min. 2200µF

Mixing up the connections can destroy the output stage.

Never disconnect the intermediate circuit if the power supply is on!

Don't pull energised plugs!

Appropriate power packs (NTS-48V-..., NTS-24V-...) and charging capacitors are available as accessories.

2.3 Inputs

All inputs are galvanically separated from the supply voltage of the PD2 by optocoupler and designed for 5 V and 24 V input signals with an input current of 10 mA.

a) Clock (CLK)

A motor step is carried out with the negative flank of the input signal. The maximum input frequency of the PD2 is 45 kHz with a minimum pulse width of 5 µs.

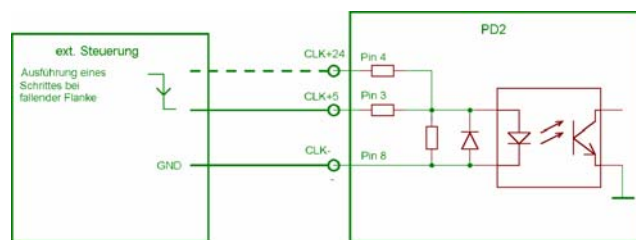

b) Direction (DIR)

The input signal Direction determines the direction in which the motor turns (CW or CCW, optocoupler wired = CW [view on engine shaft]). The direction signal must no longer be switched from a minimum of 100 µs before a motor step is carried out.

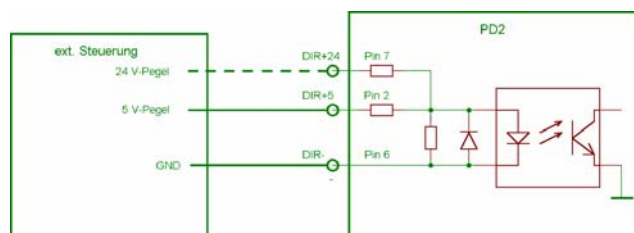

2.4 DIP- Switches

The DIP switches for adjustment of phase current and step precision are under the lower housing cover. To change the settings, the 4 countersunk bolts are to be taken out. After the lid is removed, the DIP switches are visible.

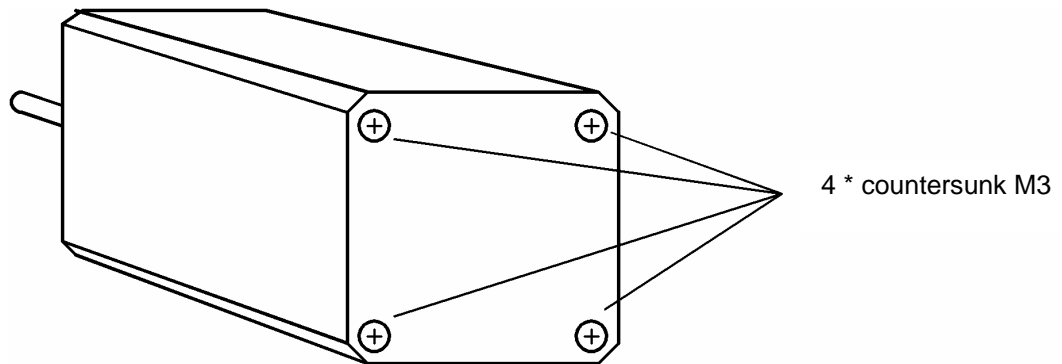

The supply voltage is to be switched off before the opening of the lid!

a) Step Mode

The step precision of the motor is determined with the switches 1 to 3. The following step precisions can be set:

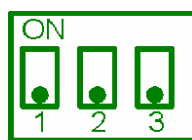

Full Step

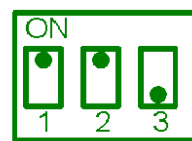

Fifth Step

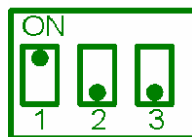

Half Step

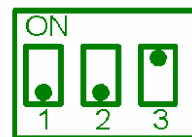

Eighth Step

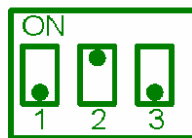

Quarter Step

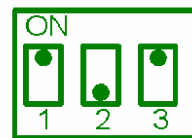

Tenth Step

b) Current Mode

The phase current is set with the switches 4 to 6:

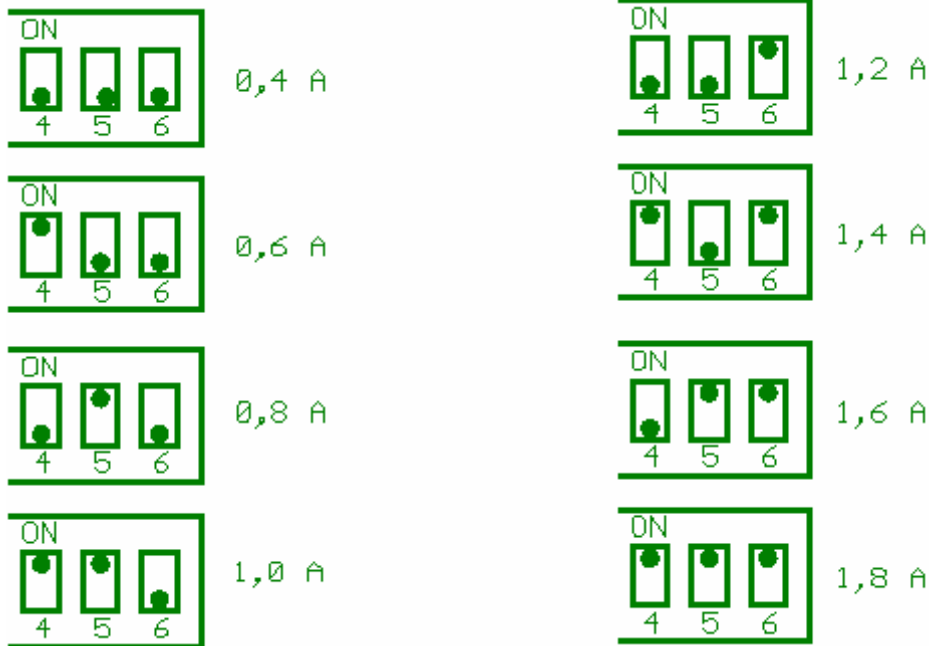

3. Commissioning

3.1 Safety instructions

Planning, connection, commissioning and maintenance of the motors and drivers is to be carried out by trained specialist personnel. In this, the state-specific regulations on accident prevention, for the setting-up of electrical and mechanical devices and on radio interference suppression are to be observed.

Before connections to the device are worked upon, always switch off the supply voltage. Never pull connections which are carrying voltage. The technical data of the motor and of the driver must always be observed. The surfaces of some devices (especially motors) can reach temperatures of more than 80°C ⇒ danger of burns if touched.

3.2 ESD safety measures

All devices which are dispatched are checked at the factory. In order to prevent long-term breakdowns due to ESD (destruction due to electrostatic discharge), extensive ESD safety measures are taken during production, from receiving to dispatching.

ESD safety measures (EN/IEC 61340-5-1) are to be observed when handling the components. No liability can be accepted for faults which are to be attributed to incorrect handling.

3.3 Measures for interference suppression

- Screening of the leads, earthing the connection of the screen on both sides on short paths (over SUBD-9 or motor)
- Use cable with wires twisted in pairs
- Keep power supply lines as short as possible
- Earth motors extensively on short paths
- Lay longer supply and control leads separately
- Connect charging capacitor as close as possible to the output stage

3.4 Connection of device

1. Setting of step mode and phase current in accordance with chapter 2.4
2. Connection of the inputs CLK, DIR in accordance with chapter 2.3
3. Checking of the supply voltage
4. Application of the supply voltage (charging capacitor!)

After the application of the supply voltage, the motor is supplied with the set phase current (current reduction after 80 ms – see 1.1). The motor then has the holding torque corresponding to the phase current.

3.5 Causes of faults

a) After switching-on:

Motor currentless:

- Check supply voltage (excess voltage or undervoltage)?
- Housing temperature too high?

b) In operation:

Motor incorrectly positioned:

- Ramp set is too steep?
- Start/stop frequency too high?
- Start/stop frequency too low or ramp too flat (motor passes through strong resonance frequencies)?
- Maximum frequency too high?
- Malfunction at input CLK or DIR?

Motor becomes excessively hot:

- Poor conduction of heat from motor flange to housing

4. Technical Characteristics

Operating Voltage	Min.: 21 V DC Typ.: 24 to 48 V DC (PD2-T42xx) Typ.: 24 V DC (PD2-T57xx) Max.: 50 V DC (PD2-T42xx) Max.: 27 V DC (PD2-T57xx)	
Input Current	2,5 A maximum	
Phase Current	0,4 to 1,8 A	
Current Setting	via DIP-Switch	
Operating Type	DMOS-Driver	
Operating mode	Full Step Half-Step Quarter-Step Fifth-Step Eighth-Step Tenth-Step	
Step angle error	± 5% (Full-Step)	
Step setting	via DIP-switch	
Step frequency	0 to max. 45 kHz Minimum pulse width 5 µs	
Inputs	4-6V or 20-26V via Optocoupler 10 mA Input current	
Current reduction	Automatically to 50 %	
Environment	Temperature	Operation: 0 to + 50° C Storage: -25° to +60° C Transport: -25° to +60° C
	Rel. Humidity	Up to max. 80% (not condensing)
Connection Type	SUBD-9	

5. Dimensions

5.1 PD2-T4218...

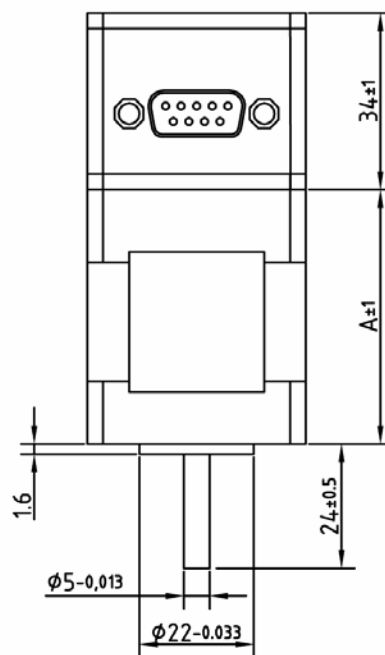
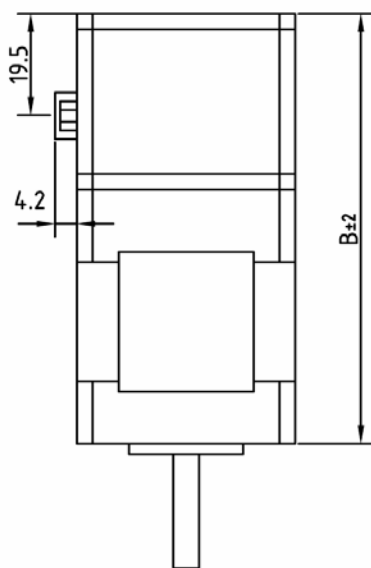
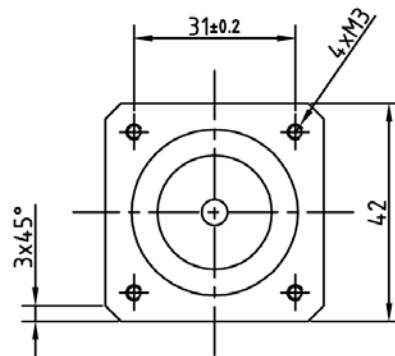

Motor	A	B
PD2-T4218S1804	33	67
PD2-T4218M1804	39	73
PD2-T4218L1804	47	81

5.2 PD2-T5718...

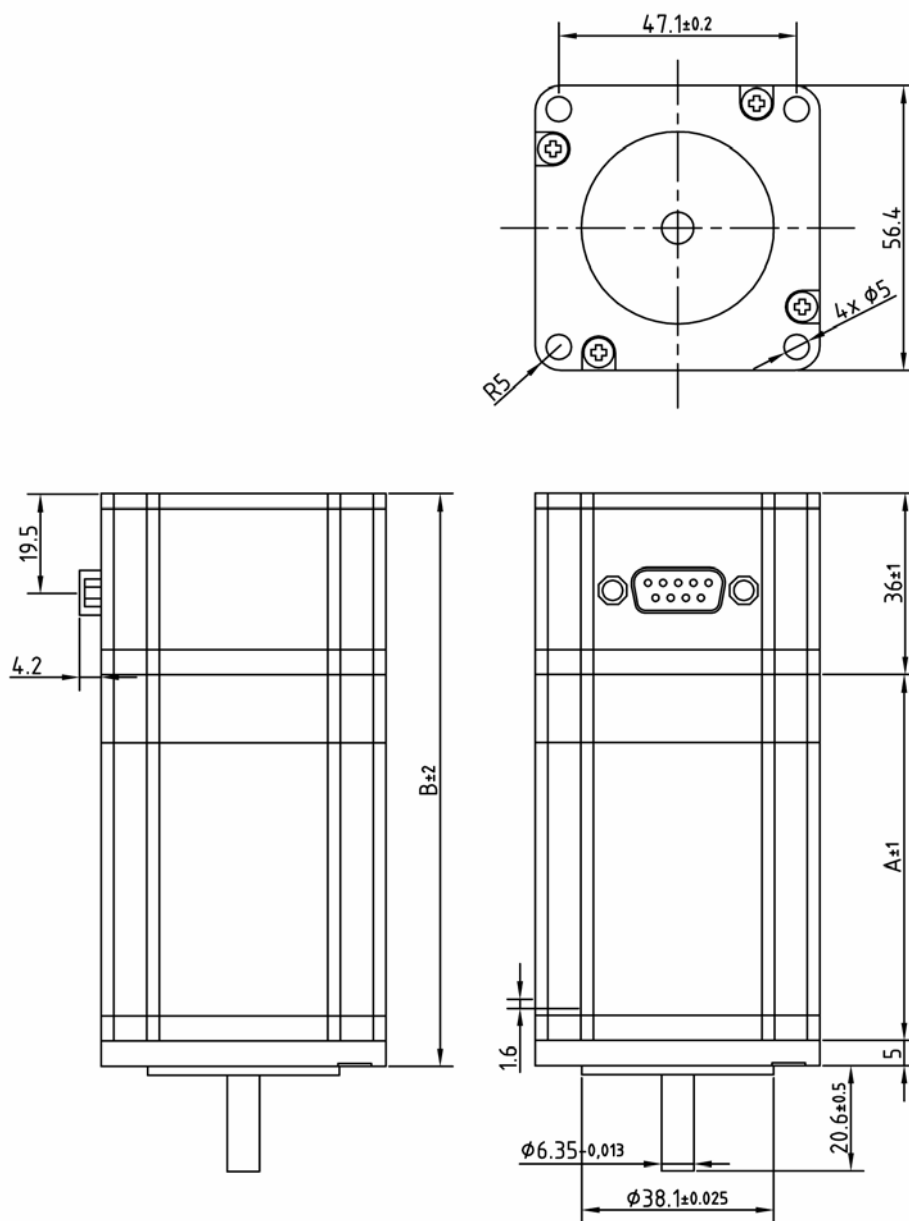

Motor	A	B	Remarks
PD2-T5718X2804	42	78	
PD2-T5718M2804	54	90	
PD2-T5718L2804	77	113	
PD2-T5718D2904	115	151	Shaft diameter 10 mm