

SPECIFICATION	CONNECTION	BIPOLAR PARALLEL
SUPPLY VOLTAGE (VDC)		24 to 48
AMPS/PHASE		* adj. to 11A (rated 7A)
HOLDING TORQUE (Nm) [lb-in]		3.2 [28.32]
DETENT TORQUE (Nm) [lb-in]		0.11 [0.974]
STEP ANGLE (°) ± ACCURACY		* 1.8 to Microstep
ROTOR INERTIA (kg-m ²) [lb-in ²]		1.0x10 ⁻⁴ [0.342]
WEIGHT (Kg) [lb]		1.7 [3.75]

* adjustable with Nanopro.

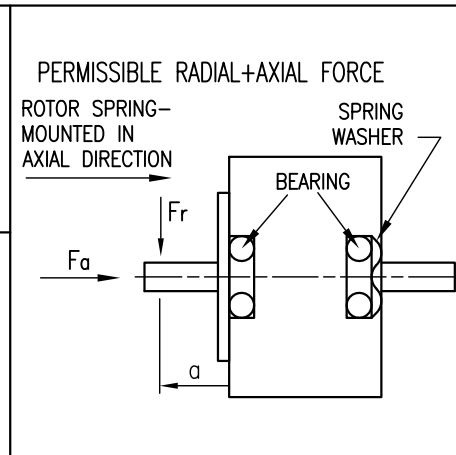
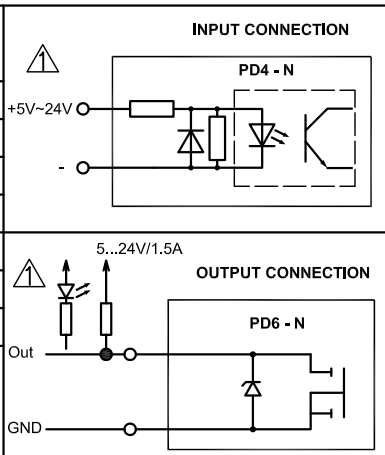

TWINTUS CONNECTOR 18 POLE		TWINTUS CONNECTOR 3 POLE	
Funktion	Pin No.	FUNKTION	PIN NO.
OUTPUT 1	1	+UB	1
OUTPUT 2	2	GND	2
OUTPUT 3	3	PROTECTIVE WIRE	3
ANALOG INPUT	4		
+UB EXTERN	5		
GND (W001)	6		
RS485 Tx+	7		
RS485 Tx-	8		
RS485 Rx-	9		
RS485 Rx+	10		
INPUT 1	11		
INPUT 2	12		
INPUT 3	13		
INPUT 4	14		
INPUT 5	15		
INPUT 6	16		
CAN -	17		
CAN +	18		

OVERTEMPERATURE PROTECTION (ELECTRONICS): 80°C	AXIAL-FORCE Fa (N)	Fa=65			
AMBIENT TEMPERATURE -10°~ 50°C [14°F ~ 122°F]	DISTANCE a (mm)	5	10	15	20
INSULATION RESISTANCE 100 MOhm (UNDER NORMAL TEMPERATURE AND HUMIDITY)	RADIAL-FORCE Fr (N)	535	355	256	200
INSULATION (MOTOR) CLASS B 130° [266°F]		AXIAL		RADIAL	
DIELECTRIC STRENGTH 500VAC FOR 1 MIN. (BETWEEN THE MOTOR COILS AND THE MOTOR CASE)	SHAFT PLAY (mm)	0.075		0.025	
AMBIENT HUMIDITY MAX. 85% (NO CONDENSATION)	AT LOAD MAX: (N)	10		5	

3	change dimension/ rework draw	01.03.16	A.S.	 Nanotec [®] PLUG & DRIVE	APVD	S.H.	25.08.10	STEPPING MOTOR DWG.NO PD6-N8918S6404-S	
2	INSERTS MUST BE GLUED WITH HOUSING	24.10.12	J.W.		CHKD				
2	ROTOR INERTIA SUPPLEMENTED	24.10.12	J.W.	Surface specification DIN ISO 1302	General tolerances DIN ISO 2768- cH	Work piece edge DIN ISO 13715	DRN	J.W.	25.08.10
REV	DESCRIPTION	DATE	DRN				SIGNATURE	DATE	